



PRICELIST 2025



Harrows, trolleys, rear loaders, bale clamps, cultivators and box rotators. Just a random selection of the machines we produced in the past 60 years and were sold to our customers worldwide. With his ambition to make farm work easier, founder Wytze Anema started designing and producing agricultural machinery in 1961. Even now, more than 60 years later, WIFO continues to hold a prominent role in the agricultural field, and our motto remains unchanged. We still work with great passion on innovative solutions that make the labour of our end users easier.

- Wytze Anema | WIFO -

A handwritten signature in black ink, appearing to be 'Wytze Anema', written over a horizontal line.



MORE THAN 60 YEARS OF EXPERIENCE

FORKLIFT ATTACHMENTS AGRICULTURAL MACHINERY

BOX ROTATORS

- 6 Box rotator
- 7 Box rotator with side-shift
- 8 Options box rotator
- 10 Attachment to box rotator

FORWARD TIPPING BOX ROTATORS

- 14 Forward tipping box rotator for telehandlers
- 15 Forward tipping box rotator 135°
- 17 Forward tipping box rotator 180° (heavy duty)
- 18 Forward tipping box rotator 150°
- 20 Attachment to forward tipping box rotator

BUCKETS

- 24 Loading bucket (fork mounted)
- 25 Loading bucket (fork carriage mounted)
- 26 Loading bucket (heavy duty, fork mounted)
- 27 Loading bucket (heavy duty, fork carriage mounted)
- 28 Loading bucket for telehandlers
- 30 Bulk loading bucket (fork mounted)
- 31 Bulk loading bucket (fork carriage mounted)
- 32 Bulk loading bucket (heavy duty, fork mounted)
- 33 Bulk loading bucket (heavy duty, fork carriage mounted)
- 34 Mechanical bucket (fork mounted)
- 35 Hydraulic bucket (fork mounted)
- 36 Tipping container (fork mounted)

SIDESHIFTS

- 42 Smart camera side-shift (three-point linkage, heavy duty)
- 44 Three-point linkage side-shift (PTO)
- 45 Three-point linkage side-shift (heavy duty)

BALE CLAMPS AND BALE SPEAR

- 48 Bale clamp for rectangular bales
- 49 Bale clamp for round bales
- 50 Bale spear

LIFTING MASTS AND PALLET CARRIERS

- 53 Lifting mast
- 54 Lifting mast (see-through model)
- 55 Accessories for lifting masts
- 57 Pallet carrier with adjustable forks

TOOL CARRIERS

- 60 Tool carrier for three-point hitch equipment
- 61 Tool carrier for three-point hitch equipment (heavy duty)
- 64 Measurement overview of attachments
- 67 Attachment parts



BOX ROTATORS

**SIMPLY!
STRONG!**

Specialist in box rotators

We have developed our range of box tippers for the careful and dosed tipping of boxes. Products such as potatoes, onions and carrots are carefully tipped out, minimising damage and bruising to the product. WIFO offers a suitable tipper for all conditions, whether the annual tipping of thousands or just hundreds of boxes, in large or confined spaces.

BOX ROTATOR



K54C-I

- Maximum box width: 1800 mm
- 180° rotation angle (left rotation as standard)
- Open construction for optimal visibility on the forklift forks
- Plug-in or folding third fork with gas spring
- Third fork in width adjustable
- High quality tipping shaft with sleeve bearing
- Including hoses and quick connectors
- Excluding forklift forks
- Equipped with durable and replaceable sprocket and gear rack (width 50 mm)



K54C-O

Type	Maximum load	Height of the fork carrier	Frontal extension length	Center of Gravity	Height third fork*	Fork carrier width	Weight	Price
K54A-I (plugin)	2.500 kg	FEM2: 407 mm	165 mm	133 mm	360 mm	1.000 mm	240 kg	€ 3.400,-
K54A-O (foldaway)	2.500 kg	FEM2: 407 mm	165 mm	158 mm	660 mm	1.000 mm	270 kg	€ 3.750,-
K54C-I (plugin)	3.500 kg	FEM3: 508 mm	185 mm	134 mm	460 mm	1.200 mm	315 kg	€ 4.025,-
K54C-O (foldaway)	3.500 kg	FEM3: 508 mm	185 mm	158 mm	760 mm	1.200 mm	345 kg	€ 4.375,-

* Calculated from the top of the fork to the bottom of the fork carrier

Options

- Rotation angle up to 200° I/O 180° € 225,-
- Right rotated instead of left rotated € 275,-
- Topfork (detachable) € 475,-
- Rapid coupling € 325,-
- Adjustable ball bearing instead of sleeve bearing € 975,-
- Attachment to frontloader or telehandler See page 10

Rapid coupling



BOX ROTATOR WITH SIDE-SHIFT



SK54C

- Maximum box width: 1800 mm
- 180° rotation angle (left rotation as standard)
- Open construction for optimal visibility on the forklift forks
- Folding third fork using gas spring
- Third fork in width adjustable
- High quality tipping shaft with sleeve bearing
- Integrated side-shift (200 mm)
- Including hoses and quick connectors
- Four-hose connections as standard
- Excluding forklift forks
- Equipped with durable and replaceable sprocket and gear rack (width 50 mm)



SK54A

Type	Maximum load	Height of the fork carrier	Frontal extension length	Center of Gravity	Height third fork*	Fork carrier width	Weight	Price
SK54A	2.500 kg	FEM2: 407 mm	173 mm	141 mm	660 mm	1.000 mm	335 kg	€ 5.525,-
SK54C	3.500 kg	FEM3: 508 mm	188 mm	145 mm	760 mm	1.200 mm	405 kg	€ 6.125,-

* Calculated from the top of the fork to the bottom of the fork carrier

Options

- Electrical hydraulic switching valve € 375,-
- Rotation angle up to 200° I/O 180° € 225,-
- Right rotated instead of left rotated € 275,-
- Topfork (detachable) € 475,-
- Adjustable ball bearing instead of sleeve bearing € 975,-
- Attachment to frontloader or telehandler See page 10

SK54C



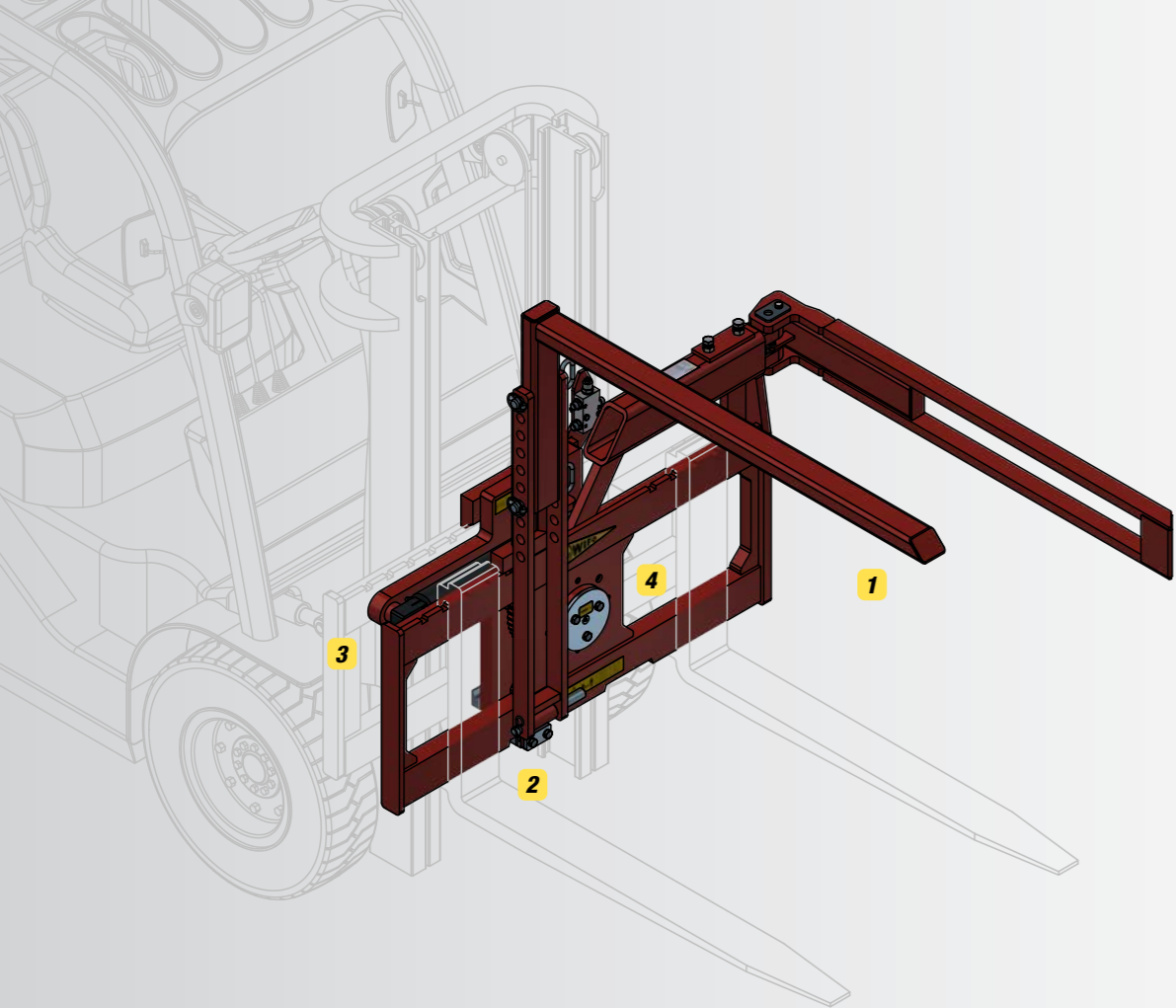

OPTIONS BOX ROTATORS

WIFO box tippers are a durable and versatile solution for efficient emptying and handling of boxes. The box tippers can be equipped with various options to suit the user's process.

- 1** Topfork for boxes without pallet
- 2** Rapid coupling for fast mounting on fork carriage
- 3** 200° rotation angle
- 4** Adjustable ball bearing for intensive use

ATTACHMENT BOX ROTATOR

To use a WIFO box rotator in combination with your frontloader or telehandler you need an adapter. The adapter consists of a fork carriage with attachment parts. The box rotator will be mounted on the adapter. Follow the next steps for the correct configuration of the adapter:

- 1 Choose the fork carriage (page 57)**
Check the height of the fork carriage (FEM size) of the rotator
 - 2 Choose attachment parts (page 67)**
Choose the attachment parts that belong to the telehandler or front loader
 - 3 Choose forklift forks (optional) (page 57)**
Optionally, you can choose for a set of forklift forks
- Box rotator + adaptor**

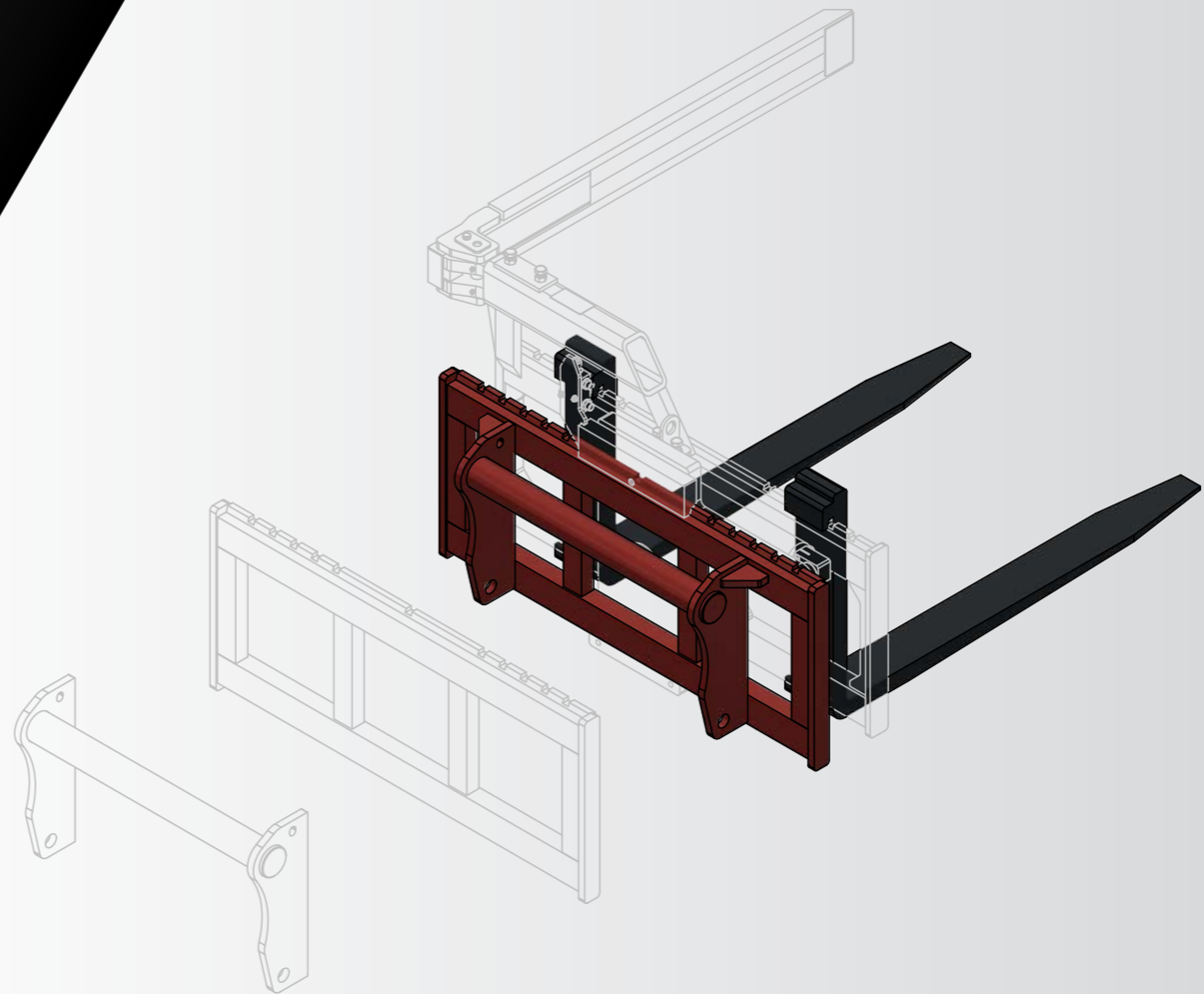

FORWARD TIPPING BOX ROTATORS

Easy tipping out of boxes in a dump bunker, planter bunker or a truck, that's possible with the WIFO forward box tippers. The forward box tippers are easy to combine with any type of forklift truck, telehandler and lifting mast and are suitable for boxes from 1200 mm to 2400 mm wide.

- ✓ Easy removal of boxes from a row (K75/K95)
- ✓ Dosed tipping of damage-sensitive products in bulk bunker or truck
- ✓ Boxes are carefully clamped to prevent damage
- ✓ Minimal dumping height to avoid product damage



FORWARD TIPPING BOX ROTATOR FOR TELEHANDLERS



K75B Maniscopeic



- 110° tipping angle + vehicle tilt angle
- Only suitable for telehandler
- Clamps exactly on the box edge (for 1600 and 1800 mm wide boxes)
- Suitable for all brands of telehandlers
- Without pivots on the side of the box
- Suitable for boxes with or without pallet
- Box depth adjustable between 850 - 1250 mm
- Box height adjustable between 800 - 1250 mm
- Complete with hydraulic hoses and quick connectors
- Standard equipped with sequence valve (2 hose connection)



▶ Video

K75B Maniscopeic



K75A:

- Suitable for box widths between 1200 - 1800 mm
- Two fixed forks as standard (790 mm center to center)
- 1 clamping cylinder

K75B:

- Suitable for box widths > 1800 mm
- With FEM2 fork carriage (1460 mm) and two adjustable forks instead of welded forks
- 2 clamping cylinders

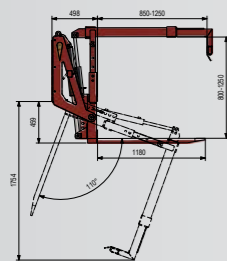

Type	Maximum load	Frontal extension length	Center of Gravity	Weight	Price
K75A	1.750 kg	500 mm	500 mm	615 kg	€ 8.550,-
K75B	2.750 kg	570 mm	531 mm	840 kg	€ 11.400,-

Options

- Roll-over upper clamp for boxes > 1200 mm
- With four instead of two forks (for box width 2400 mm)
- Attachment parts for telehandler

€ 550,-

€ 2050,-

See page 67

FORWARD TIPPING BOX ROTATOR 135°



K80-1600



- 135° tipping angle
- Suitable for boxes with or without pallet
- Clamps exactly on the box edge
- Box depth adjustable between 850 - 1200 mm
- Box height adjustable between 850 - 1250 mm
- With rapid connection system suitable for FEM2 and FEM3
- Standard with 2 fixed forks
- Complete with hoses and quick connectors
- Standard equipped with sequence valve (2 hose connection)



▶ Video

K80-1600



Type	Maximum load	Maximum rotation capacity	Frontal extension length	Center of Gravity	Maximum box width	Fork distance (center to center)	Weight	Price
K80-1600	2.500 kg	1.750 kg	440 mm	560 mm	1.600 mm	800 mm	640 kg	€ 8.550,-
K80-1800	2.500 kg	1.750 kg	440 mm	560 mm	1.800 mm	800 mm	670 kg	€ 8.650,-

Options

- Attachment parts for frontloader/telehandler

See page 20

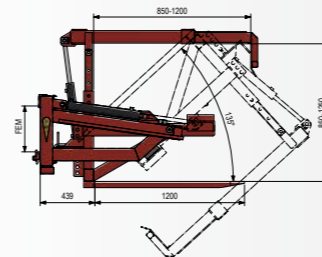



FORWARD TIPPING BOX ROTATOR 180° (HEAVY DUTY)



▶ Video

- 180° tipping angle
- Standard equipped with roll-over clamp
- Suitable for boxes with or without pallet
- For box height between 800 - 1250 mm
- Rapid connection system FEM2 and FEM3 (K90-2400: FEM3 and FEM4)
- 2 adjustable forks as standard (K90-2400: 4 adjustable forks)
- Complete with hydraulic hoses and quick connectors
- Standard equipped with sequence valve (2 hose connection)

K90-1600



K90-1600



Type	Maximum load	Maximum rotation capacity	Frontal extension length	Center of Gravity	Maximum box width	Weight	Price
K90-1600	2.750 kg	2.000 kg	460 mm	530 mm	1.600 mm	945 kg	€ 12.950,-
K90-1800	2.750 kg	2.000 kg	460 mm	530 mm	1.800 mm	970 kg	€ 13.075,-
K90-2000	2.750 kg	2.000 kg	460 mm	530 mm	2.000 mm	995 kg	€ 13.200,-
K90-2240	2.750 kg	2.000 kg	460 mm	460 mm	2.240 mm	1.020 kg	€ 13.325,-
K90-2400	2.750 kg	2.000 kg	460 mm	560 mm	2.400 mm	1.115 kg	€ 14.350,-

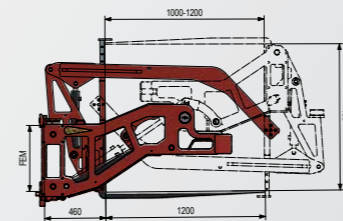

Options

- Depth adjustment for various boxes (1000 - 1100 mm deep)
- Attachment parts for telehandler

€ 325,-
See page 20

FORWARD TIPPING BOX ROTATOR 150°



K95

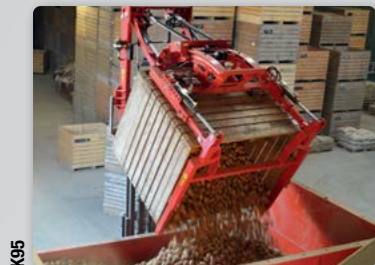

K95

- Without pivots on the side of the box
- 150° tipping angle
- Suitable for boxes with or without pallet
- Adjustable for box depths between 1000 - 1200 mm
- Adjustable for box height between 975 - 1275 mm
- Rapid connection system FEM3
- 2 adjustable forks as standard
- Complete with hoses and quick connectors
- Standard equipped with sequence valve (2 hose connection)



▶ Video



K95

Type	Maximum load	Maximum rotation capacity	Frontal extension length	Center of Gravity	Weight	Price
K95	2.750 kg	2.000 kg	460 mm	355 mm	975 kg	€ 17.950,-

Options

- Rapid connection system FEM4 (I/O FEM3) € 300,-
- Upper clamp exactly on the box edge for boxes of 1800 mm width € 175,-
- Upper clamp with extendable parts for boxes width from 1800 - 2400 mm € 150,-
- Equipped with an extended fork carriage and 4 adjustable forks (for 2400 mm boxes) € 1.150,-
- Attachment for telehandler

See page 20

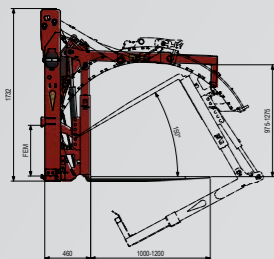

ATTACHMENT FORWARD TIPPING BOX ROTATOR

To use a WIFO forward tipping box rotator in combination with your telehandler you need an adapter. The adapter consists of a fork carriage with attachment parts. The forward tipping box rotator will be mounted on the adapter. Follow the next steps for the correct configuration of the adaptor:

- 1** Choose fork carriage (page 57)
Check the height of the fork carriage (FEM size) of the forward tipping rotator
 - 2** Choose attachment parts (page 67)
Choose the attachment parts that belong to the telehandler
- Forward tipping box rotator + adaptor

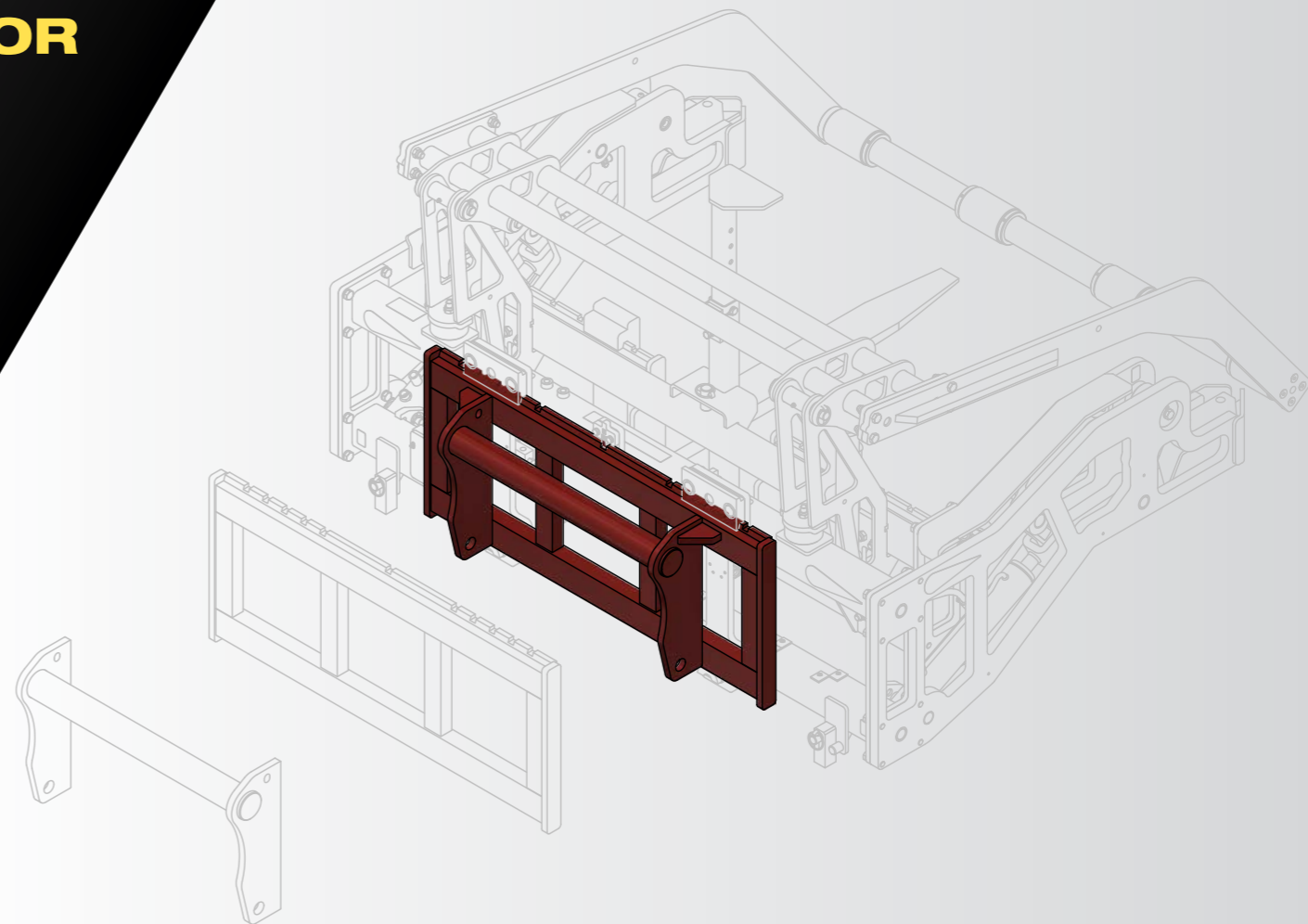

BUCKETS

Even more efficient loading and unloading

WIFO loading buckets stand for durability and quality. The potato loading buckets are the solution when it comes to shovelling, for example, damage-sensitive products such as potatoes and onions, but the buckets are also extremely suitable for grain. The range of bulk buckets is designed for bulk products such as grain, soil, gravel or sand. The buckets are suitable for any type of forklift, telehandler and shovel.

- ✓ Suitable for damage-sensitive products such as potatoes, onions, carrots etc.
- ✓ High quality and long service life
- ✓ Simple and efficient loading and unloading of bulk products
- ✓ Suitable for any type of forklift, telehandler and shovel

**SIMPLY!
STRONG!**

LOADING BUCKET (FORK MOUNTED)



HOD-200 stainless steel bottom

- Suitable for products vulnerable to damage
- Double hinge device for a minimum of loss in dump height
- See-through grille for optimal visibility
- 6 mm plate thickness
- Equipped with manganese wearing strip (80x15 mm)
- Fork pockets: 159x69-L1197 mm, c.t.c. 830 mm
- Including hydraulic hoses and quick connectors



HOD-200 stainless steel bottom

Type	Bucket width	Bucket depth	Bucket height	Volume	Center of Gravity	Weight	Price	Additional charge stainless steel bottom plate
HOD-150	1.500 mm	1.550 mm	850 mm	1.100 l	900 mm	405 kg	€ 3.775,-	€ 525,-
HOD-175	1.750 mm	1.550 mm	850 mm	1.300 l	900 mm	440 kg	€ 3.875,-	€ 575,-
HOD-200	2.000 mm	1.550 mm	850 mm	1.500 l	900 mm	475 kg	€ 3.975,-	€ 625,-
HOD-225	2.250 mm	1.550 mm	850 mm	1.700 l	900 mm	510 kg	€ 4.075,-	€ 675,-

Options

- Transparent cover-plate mounted on see-through grille (for grain etc.)
- Detachable frame (+20% content; not for products vulnerable to damage)
- Straight edges (not possible in combination with detachable frame)

€ 75,-
€ 675,-
€ 225,-

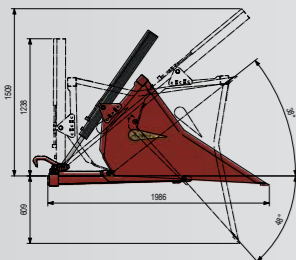

LOADING BUCKET (FORK CARRIAGE MOUNTED)



HOD-150F

- Suitable for products vulnerable to damage
- Frame with rapid coupling FEM2 and FEM3 directly onto fork carriage
- See-through grille for optimal visibility
- 6 mm plate thickness
- Equipped with manganese wearing strip (80x15 mm)
- Including hydraulic hoses and quick connectors



HOD-150F

Type	Bucket width	Bucket depth	Bucket height	Volume	Center of Gravity	Weight	Price	Additional charge stainless steel bottom plate
HOD-150F	1.500 mm	1.550 mm	850 mm	1.100 l	800 mm	400 kg	€ 4.200,-	€ 525,-
HOD-175F	1.750 mm	1.550 mm	850 mm	1.300 l	800 mm	435 kg	€ 4.300,-	€ 575,-
HOD-200F	2.000 mm	1.550 mm	850 mm	1.500 l	800 mm	470 kg	€ 4.400,-	€ 625,-
HOD-225F	2.250 mm	1.550 mm	850 mm	1.700 l	800 mm	505 kg	€ 4.500,-	€ 675,-

Options

- Transparent cover-plate mounted on see-through grille (for grain etc.)
- Detachable frame (+20% content; not for products vulnerable to damage)
- Straight edges (not possible in combination with detachable frame)

€ 75,-
€ 675,-
€ 225,-

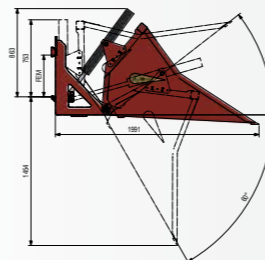

LOADING BUCKET (HEAVY DUTY, FORK MOUNTED)



HOD-Z-250 stainless steel bottom

- Suitable for products vulnerable to damage
- Double hinge device for a minimum of loss in dump height
- See-through grille for optimal visibility
- 8 mm plate thickness
- All pivots equipped with bearings
- Equipped with boron wearing strip (150x20 mm)
- Fork pockets: 153x69xL1197 mm, c.t.c. 830 mm
- Including hoses and quick connectors



HOD-Z-250

Type	Bucket width	Bucket depth	Bucket height	Volume	Center of Gravity	Weight	Price	Additional charge stainless steel bottom plate
HOD-Z-200	2.000 mm	1.550 mm	850 mm	1.500 l	900 mm	650 kg	€ 6.100,-	€ 650,-
HOD-Z-225	2.250 mm	1.550 mm	850 mm	1.700 l	900 mm	675 kg	€ 6.225,-	€ 700,-
HOD-Z-250	2.500 mm	1.550 mm	850 mm	1.900 l	900 mm	700 kg	€ 6.900,-	€ 750,-
HOD-Z-275	2.750 mm	1.550 mm	850 mm	2.100 l	900 mm	725 kg	€ 7.125,-	€ 800,-

HOD-Z-200/225: 1 cylinder

HOD-Z-250/275: 2 cylinders

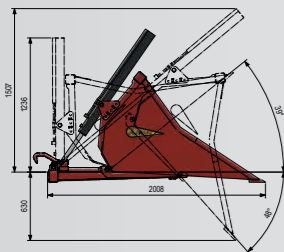

Options

- Transparent cover-plate mounted on see-through grille (for grain etc.)
- Detachable frame (+20% content; not for products vulnerable to damage)
- Straight edges (not possible in combination with detachable frame)

€ 75,-

€ 675,-

€ 225,-

LOADING BUCKET (HEAVY DUTY, FORK CARRIAGE MOUNTED)



HOD-Z-250F

- Suitable for products vulnerable to damage
- Frame with rapid coupling directly onto fork carriage
- See-through grille for optimal visibility
- 8 mm plate thickness
- All pivots equipped with bearings
- With boron wearing strip (150x20 mm)
- Complete with hoses and quick connectors



HOD-Z-250F

Type	Bucket width	Bucket depth	Bucket height	Volume	Center of Gravity	Weight	Price	Additional charge stainless steel bottom plate
HOD-Z-200F	2.000 mm	1.550 mm	850 mm	1.500 l	800 mm	750 kg	€ 6.950,-	€ 650,-
HOD-Z-225F	2.250 mm	1.550 mm	850 mm	1.700 l	800 mm	795 kg	€ 7.175,-	€ 700,-
HOD-Z-250F	2.500 mm	1.550 mm	850 mm	1.900 l	800 mm	925 kg	€ 7.875,-	€ 750,-
HOD-Z-275F	2.750 mm	1.550 mm	850 mm	2.100 l	800 mm	970 kg	€ 8.100,-	€ 800,-

HOD-Z-200/225F: 1 cylinder, fork carriage FEM3/3

HOD-Z-250/275F: 2 cylinders, fork carriage FEM3/4

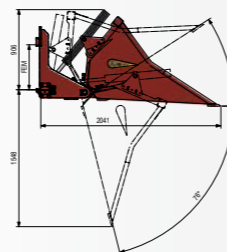

Options

- Transparent cover-plate mounted on see-through grille (for grain etc.)
- Detachable frame (+20% content; not for products vulnerable to damage)
- Straight edges (not possible in combination with detachable frame)

€ 75,-

€ 675,-

€ 225,-

LOADING BUCKET FOR TELEHANDLERS



HOD-V-250 Volvo L30



- Suitable for products vulnerable to damage
- Attachments for all telehandlers brands
- See-through grille for optimal visibility
- 10 mm plate thickness
- With boron wearing strip (150x20 mm)

HOD-V-250 Volvo L30



Type	Bucket width	Bucket depth	Bucket height	Volume	Center of Gravity	Weight	Price	Additional charge stainless steel bottom plate
HOD-V-225	2.250 mm	1.550 mm	850 mm	1.700 l	520 mm	635 kg	€ 4.650,-	€ 700,-
HOD-V-250	2.500 mm	1.550 mm	850 mm	1.900 l	520 mm	680 kg	€ 4.900,-	€ 750,-
HOD-V-275	2.750 mm	1.550 mm	850 mm	2.100 l	520 mm	750 kg	€ 5.150,-	€ 800,-
HOD-V-300	3.000 mm	1.550 mm	850 mm	2.300 l	520 mm	795 kg	€ 5.400,-	€ 850,-

Options

- Transparent cover-plate mounted on see-through grille (for grain etc.) € 125,-
- Detachable frame (+20% content; not for products vulnerable to damage) € 675,-
- Straight edges (not possible in combination with detachable frame) € 225,-
- Attachment parts for telehandler/shovel

See page 67

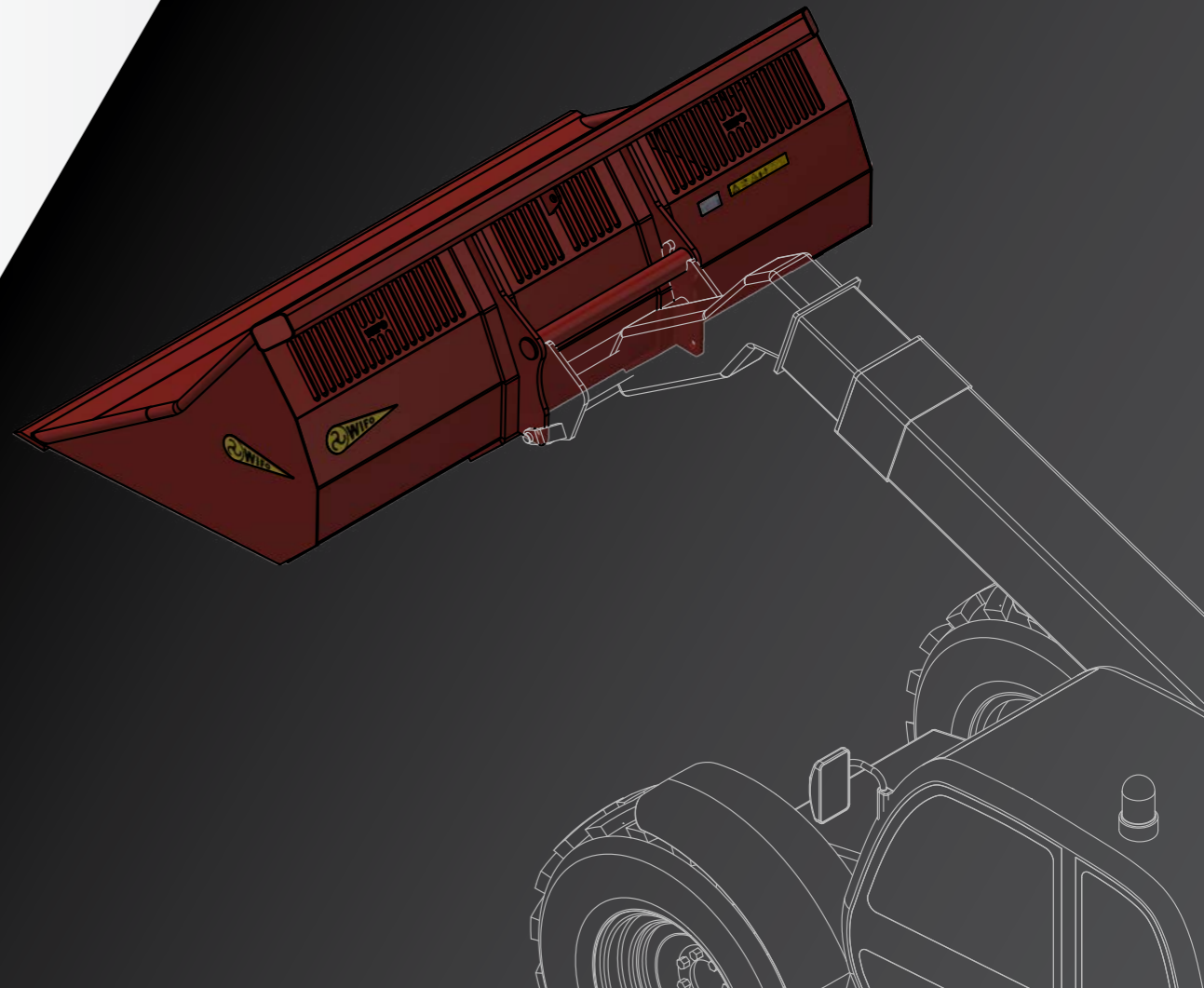
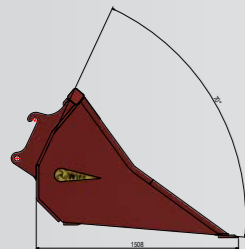

BULK LOADING BUCKET (FORK MOUNTED)



HO-150

- Suitable for bulk products such as cereals, fertiliser, soil, etc.
- Double hinge device for a minimum of loss in dump height
- 6 mm plate thickness
- With manganese wearing strip (80x15 mm)
- Fork pockets: 159x69-L1197 mm, c.t.c. 830 mm
- Complete with hydraulic hoses and quick connectors



HO-150

Type	Bucket width	Bucket depth	Bucket height	Volume	Center of Gravity	Weight	Price
HO-125	1.250 mm	1.300 mm	860 mm	900 l	800 mm	415 kg	€ 3.700,-
HO-150	1.500 mm	1.300 mm	860 mm	1.100 l	800 mm	445 kg	€ 3.800,-
HO-175	1.750 mm	1.300 mm	860 mm	1.300 l	800 mm	475 kg	€ 3.900,-
HO-200	2.000 mm	1.300 mm	860 mm	1.500 l	800 mm	505 kg	€ 4.000,-
HO-225	2.250 mm	1.300 mm	860 mm	1.700 l	800 mm	535 kg	€ 4.100,-

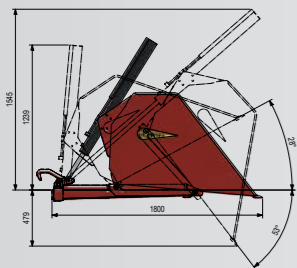

BULK LOADING BUCKET (FORK CARRIAGE MOUNTED)



HO-125F

- Suitable for bulk products such as cereals, fertiliser, soil, etc.
- Frame with rapid coupling FEM2 and FEM3, directly onto fork carriage
- 6 mm plate thickness
- With manganese wearing strip (80x15 mm)
- Complete with hoses and quick connectors



HO-125F

Type	Bucket width	Bucket depth	Bucket height	Volume	Center of Gravity	Weight	Price
HO-125F	1.250 mm	1.300 mm	860 mm	900 l	645 mm	420 kg	€ 4.100,-
HO-150F	1.500 mm	1.300 mm	860 mm	1.100 l	645 mm	450 kg	€ 4.200,-
HO-175F	1.750 mm	1.300 mm	860 mm	1.300 l	645 mm	480 kg	€ 4.300,-
HO-200F	2.000 mm	1.300 mm	860 mm	1.500 l	645 mm	510 kg	€ 4.400,-
HO-225F	2.250 mm	1.300 mm	860 mm	1.700 l	645 mm	540 kg	€ 4.500,-

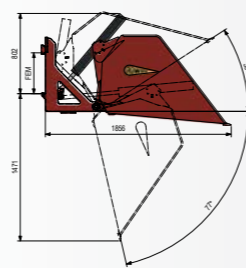

BULK LOADING BUCKET (HEAVY DUTY, FORK MOUNTED)



HO-250-ZI

- Loading bucket for industrial applications
- Double hinge device for a minimum of loss in dump height
- All rotating points have bearings
- 8 mm plate thickness
- With boron wearing strip (150x20 mm)
- Fork pockets: 153x69x1197 mm, c.t.c. 830 mm
- Complete with hoses and quick connectors
- Equipped with 2 cylinders



HO-250-ZI

Type	Bucket width	Bucket depth	Bucket height	Volume	Center of Gravity	Weight	Price
HO-200-ZI	2.000 mm	1.465 mm	1.150 mm	1.950 l	920 mm	840 kg	€ 7.100,-
HO-225-ZI	2.250 mm	1.465 mm	1.150 mm	2.200 l	920 mm	890 kg	€ 7.275,-
HO-250-ZI	2.500 mm	1.465 mm	1.150 mm	2.450 l	920 mm	940 kg	€ 7.450,-
HO-275-ZI	2.750 mm	1.465 mm	1.150 mm	2.700 l	920 mm	990 kg	€ 7.625,-
HO-300-ZI	3.000 mm	1.465 mm	1.150 mm	2.950 l	920 mm	1.040 kg	€ 7.800,-

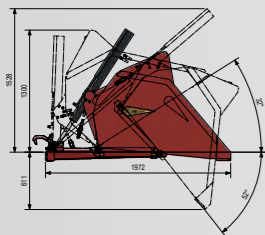

BULK LOADING BUCKET (HEAVY DUTY, FORK CARRIAGE MOUNTED)



HO-250-ZIF

- Loading bucket for industrial applications
- Frame with rapid coupling FEM3 and FEM4 directly onto fork carriage
- Short attachment length to fork carriage
- All rotating points have bearings
- 8 mm plate thickness
- With boron wearing strip (150x20 mm)
- Complete with hoses and quick connectors
- Equipped with 2 cylinders



HO-250-ZIF

Type	Bucket width	Bucket depth	Bucket height	Volume	Center of Gravity	Weight	Price
HO-200-ZIF	2.000 mm	1.500 mm	1.100 mm	1.950 l	800 mm	920 kg	€ 8.200,-
HO-225-ZIF	2.250 mm	1.500 mm	1.100 mm	2.200 l	800 mm	970 kg	€ 8.375,-
HO-250-ZIF	2.500 mm	1.500 mm	1.100 mm	2.450 l	800 mm	1.020 kg	€ 8.550,-
HO-275-ZIF	2.750 mm	1.500 mm	1.100 mm	2.700 l	800 mm	1.070 kg	€ 8.725,-
HO-300-ZIF	3.000 mm	1.500 mm	1.100 mm	2.950 l	800 mm	1.120 kg	€ 8.900,-

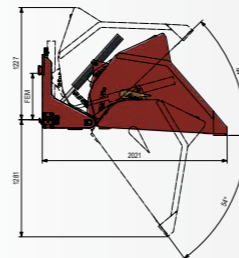

▶ Video

MECHANICAL BUCKET (FORK MOUNTED)



MO-800

- Mechanical bucket for bulk products
- Lever can be placed on the right and left side
- Low loss on discharge
- 6 mm plate thickness
- With manganese wearing strip (80x15 mm)
- Fork pockets: 159x69-L1197 mm, c.t.c. 830 mm
- Maximum load 750 kg
- External bucket width: + 130 mm



MO-800

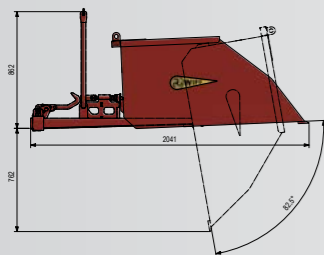

Type	Bucket width	Bucket depth	Bucket height	Volume	Center of Gravity	Weight	Price
MO-600	1.000 mm	1.300 mm	600 mm	600 l	885 mm	290 kg	€ 2.200,-
MO-800	1.300 mm	1.300 mm	600 mm	800 l	885 mm	320 kg	€ 2.325,-

HYDRAULIC BUCKET (FORK MOUNTED)



MO-150

- Bucket suitable for sand, gravel, soil etc.
- 6 mm plate thickness
- Fork pockets: 180x59-L800 mm, c.t.c. 760 mm
- Complete with hydraulic hoses and quick connectors



MO-150

Type	Bucket width	Bucket depth	Bucket height	Volume	Center of Gravity	Weight	Price
MO-100	1.000 mm	1.000 mm	560 mm	290 l	1.380 mm	180 kg	€ 2.300,-
MO-150	1.500 mm	1.000 mm	560 mm	435 l	1.380 mm	230 kg	€ 2.400,-

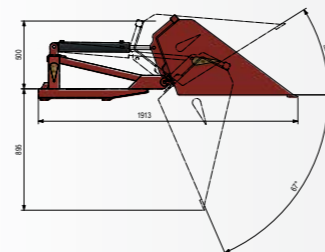

TIPPING CONTAINER (FORK MOUNTED)



KC-1000

- Mechanical tipping container for removal of products, waste etc.
- Handle can be placed on the right or left side
- Low loss on discharge
- 4 mm plate thickness
- Fork pockets: 159x74-L990 mm, c.t.c. 735 mm
- Maximum load 750 kg
- External container width: +130 mm



KC-1000 + wheels

Type	Bucket width	Bucket depth	Bucket height	Volume	Center of Gravity	Weight	Price
KC-1000	1.000 mm	1.400 mm	820 mm	1.000 l	1.130 mm	250 kg	€ 1.925,-
KC-1300	1.300 mm	1.400 mm	820 mm	1.300 l	1.150 mm	280 kg	€ 2.025,-

Options

- Wheels (2 fixed wheels and 2 braked swivel wheels)

€ 350,-

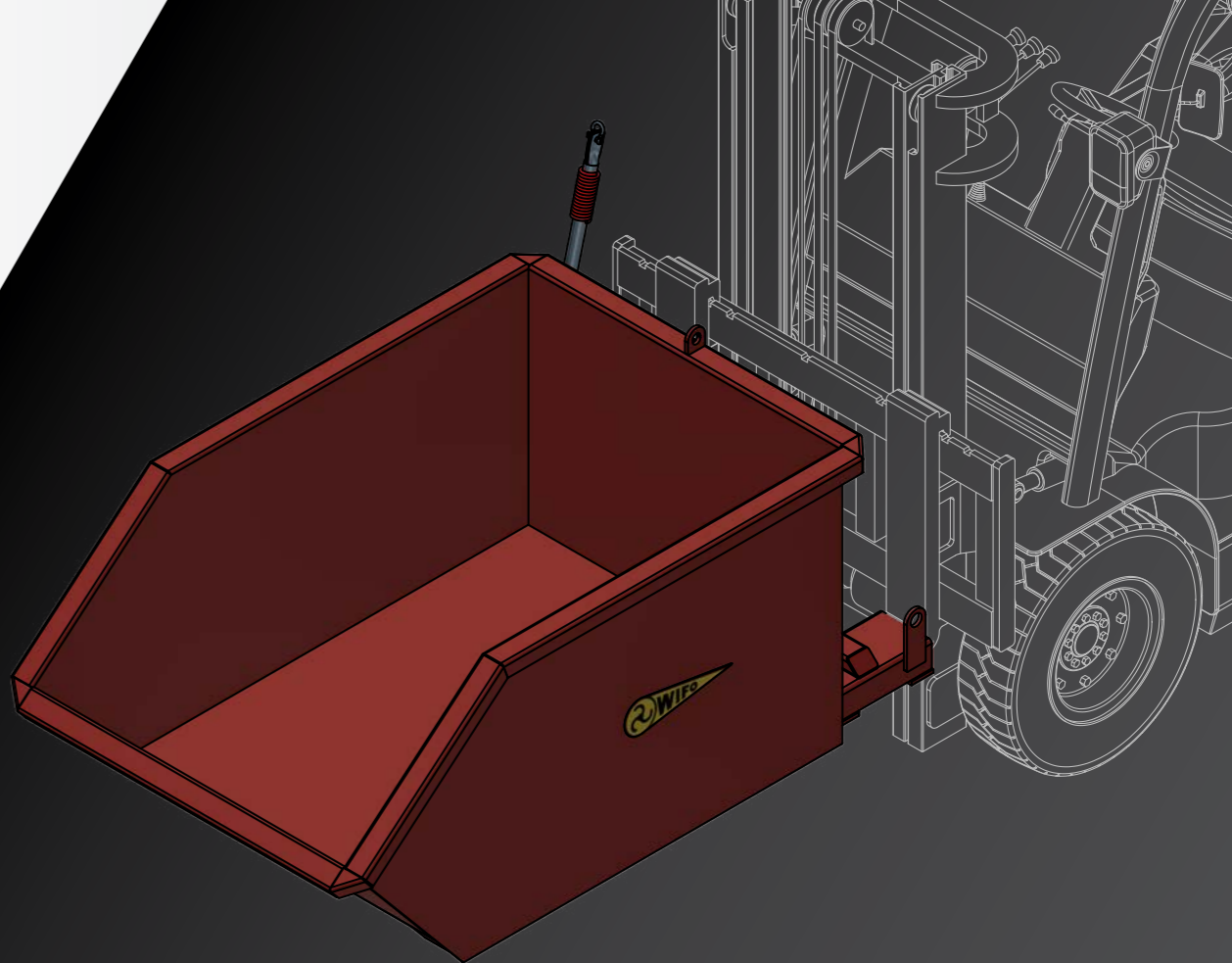
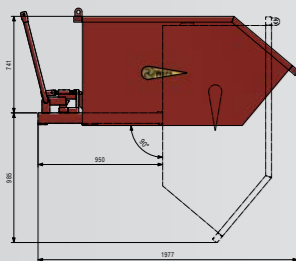

WIFO CRAFTMANSCHIP

We are WIFO!

We stand for high-quality agricultural machinery and attachments for forklifts and telehandlers, keeping the entire production process from design to final assembly in-house. Our professionals work with an eye for detail and strive for perfection in material and execution, supported by advanced technologies such as CNC machines, welding robots and laser cutters. Since 1961, WIFO has been a global leader in the agricultural, logistics and industrial sectors. Countless machines, such as box rotators, buckets and planters, leave our factory in Ferwert every day, recognisable by their distinctive WIFO red colour.





SMART CAMERA SIDESHIFT

HIGHLY ACCURATE

Weeding can now be even more precise with WIFO's Smart Camera Sideshift. The camera simply follows the crop rows and uses the sideshift to position the weeder to within a few centimetres of the crop. The Tillet and Hague smart camera distinguishes weeds based on different shades of greens and automatically positions the weeder to the correct position. This allows even tighter and more precise weeding.



VIDEO
Scan the QR-code

SMART CAMERA SIDE-SHIFT FOR THREE-POINT LINKAGE (HEAVY DUTY)



DSD-Z-300



DSD-Z-300



DSD-Z-300

- Camera-controlled sideshift for weeding e.g. corn, beets and onions
 - Precise weeding at high speeds up to 20 km/h
 - Standard with load-bearing gauge wheels for track widths from 1.5 m - 2.25 m (optional to 3,20 m)
 - Total sideshift range of 300 mm
 - Linear shift across hard chromed axes
 - Equipped with high resolution camera and color recognition
-
- Three-point hitch: Cat. 2 and 3 (machine side)
 - Bolted, in height adjustable, catch hooks (Cat. 2) with automatic safety lock (tool side)
 - Suitable in combination with any type of weeder



▶ Video

Type	Maximum load	Frontal extension length	Sideshift reach	Weight	Price
DSD-Z-300	4.000 kg	425 mm	300 mm	400 kg	€ 26.950,-

i Other terms and conditions apply to the Smart Camera Sideshift

Options

- LED work lights for optimal crop recognition € 550,-
 - Manual control € 750,-
 - Support wheels up to 3.20 m € 500,-
-
- Without stabilizing wheels and attachments (front linkage) Less price - € 750,-



DSD-Z-300

THREE-POINT LINKAGE SIDE-SHIFT (PTO)



DSD-500

- For shifting PTO driven three-point linkage equipment
- Three-point linkage, DSD-500: Cat. 2, DSD-600: Cat. 2 and 3
- Adjustable lower link hooks, DSD-500: Cat. 2, DSD-600: Cat. 2 or 3
- Complete with hydraulic hoses and quick connectors



DSD-600

Type	Maximum load	Frontal extension length	Sideshift reach	Weight	Price Cat. 2*	Price Cat. 3*
DSD-500	1.500 kg	312 mm	500 mm	230 kg	€ 3.400,-	-
DSD-600	3.000 kg	475 mm	600 mm	475 kg	€ 6.150,-	€ 6.300,-

* Three-point linkage attachment side



DSD-600

THREE-POINT LINKAGE SIDE-SHIFT (HEAVY DUTY)



DSD-Z-500

- Sideshift for three-point linkage equipment
- Three-point linkage attachment: Cat. 2 and Cat. 3
- Standard sideshift reach: 500 mm
- Side-shift guides have bearings over hard-chromed axes
- Fixed lower link hooks (Cat. 2 or Cat. 3) with automatic safety interlock
- Complete with hydraulic hoses and quick connectors



DSD-Z-500

Type	Maximum load	Frontal extension length	Sideshift reach	Weight	Price Cat. 2*	Price Cat. 3*
DSD-Z-500	4.000 kg	475 mm	500 mm	400 kg	€ 6.700,-	€ 6.800,-

* Three-point linkage attachment side



DSD-Z-500

BALE CLAMPS | BALE SPEAR

Years of experience in high-quality bale clamps

Discover now the reliability and efficiency of WIFO bale clamps. Designed specifically for the agricultural sector, the bale clamps are the solution for moving, transporting and stacking hay and straw bales. The high-quality clamps are so constructed and equipped with a non-return pressure relief valve that prevents damage to the wrap. Improve your efficiency and productivity with WIFO bale clamps now!



BALE CLAMP FOR RECTANGULAR BALES



BKP-UF Euro



- Compact baleclamp for wrapped rectangular bales
- Also suitable for round bales
- Heavy duty clamp arms made out of thick-walled tubing
- Narrow clamp arm allows passage between close-lying bales
- With raised rear section for second bale
- With controlled non-return valve and pressure relief valve as standard (ex mill at 140 bar)
- Including hydraulic hoses and quick connectors

BKP-UF Euro



Type	Number of bales	Clamp reach	Min. machine width	Length clamping arm	Max. capacity	Weight	Price
BKP-UF	1 + 1	750-2.050 mm	1.150 mm	1.100 mm	1.500 kg	325 kg	€ 2.950,-

Options

- Front loader connection (Euro)
- Attachment parts for frontloader/telehandler/shovel

€ 225,-
See page 67

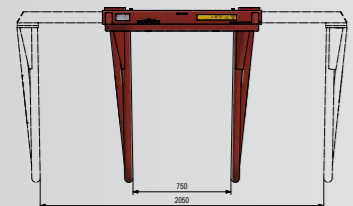

BALE CLAMP FOR ROUND BALES



BKP Euro



- Bale clamp for round bales only
- Heavy duty baleclamp arm made out of thick-walled tubing
- Clamp arms optimally curved
- With controlled non-return valve and pressure relief valve as standard (ex mill at 170 bar)
- Including hydraulic hoses and quick connectors

BKP Euro



Type	Number of bales	Bale diameter	Max. capacity	Weight	Price
BKP	1	900-1.300 mm	1.500 kg	250 kg	€ 2.475,-

Options

- Front loader connection (Euro)
- Attachment parts for frontloader/telehandler/shovel



▶ Video

€ 225,-
See page 67

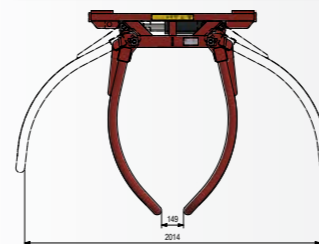

BALE SPEAR



BP-3 Euro



- Bale spear suitable for both round and rectangular bales
- Universal mainframe with up to 5 bolted spears

BP-3 Euro + straw bale clamp



Type	Width	Spears	Spear distance center to center	Max. capacity	Weight	Price
BP-2	1.500 mm	2 x Ø45-L980 mm	720/1430 mm	1.000 kg	95 kg	€ 850,-
BP-3	1.500 mm	3 x Ø45-L980 mm	360/720 mm	1.500 kg	105 kg	€ 950,-
BP-5	1.500 mm	5 x Ø45-L980 mm	360 mm	1.500 kg	125 kg	€ 1.150,-

Options

- Front loader connection (Euro) € 225,-
- Transport protection spears € 275,-
- Raised rear section (2000 mm) € 250,-
- Straw bale clamp (incl. raised rear section) € 950,-
- Spear length 1250 mm instead of 980 mm (per spear) € 35,-
- Attachment parts for frontloader/telehandler

See page 67

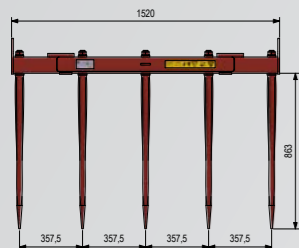

LIFTING MASTS



LIFTING MAST



HM280/1600

- Category 2 three-point linkage as standard
- Mast width 525 mm
- Fork carriage width 1000 mm (FEM2)
- Fork length 1190 mm (foldaway)
- Adjustable fork width
- Maximum operating pressure 180 bar
- Drive-through height calculated with lower hitch point height 300 mm above the ground
- With wagon drawbar
- Complete with hydraulic hoses and quick connectors

i This type of lifting mast is not suitable in combination with a bale clamp, box rotator etc.



HM280/1600

Type	Lift height	Lifting capacity	Headroom	Weight	Price
HM200/1000	2.000 mm	1.000 kg	1.800 mm	370 kg	€ 4.500,-
HM240/1000	2.400 mm	1.000 kg	2.000 mm	385 kg	€ 4.600,-
HM280/1000	2.800 mm	1.000 kg	2.200 mm	400 kg	€ 4.700,-
HM200/1600	2.000 mm	1.600 kg	1.800 mm	380 kg	€ 4.650,-
HM240/1600	2.400 mm	1.600 kg	2.000 mm	395 kg	€ 4.750,-
HM280/1600	2.800 mm	1.600 kg	2.200 mm	410 kg	€ 4.850,-

Options

- Lifting mast accessories

See page 55

LIFTING MAST (SEE-THROUGH MODEL)



HMD 240/2000



- Category 2 three-point linkage as standard
- Mast width 770 mm
- Fork carriage width 1200 mm (FEM2)
- Fork length 1190 mm (foldaway)
- Adjustable fork width
- Maximum operating pressure 180 bar
- Drive-through height calculated with lower hitch point height 300 mm above the ground
- With wagon drawbar
- Complete with hydraulic hoses and quick connectors

i Tractor specifications desired for solid construction of the lifting mast on the front of the tractor.
This type of lifting mast is not suitable in combination with a forward tipping box rotator.

HMD 240/2000



Type	Lift height	Lifting capacity	Headroom	Weight	Price
HMD 200/2000	2.000 mm	2.000 kg	1.800 mm	595 kg	€ 6.600,-
HMD 240/2000	2.400 mm	2.000 kg	2.000 mm	615 kg	€ 6.700,-
HMD 280/2000	2.800 mm	2.000 kg	2.200 mm	635 kg	€ 6.800,-
HMD 240/2500	2.400 mm	2.500 kg	2.000 mm	625 kg	€ 7.050,-
HMD 280/2500	2.800 mm	2.500 kg	2.200 mm	645 kg	€ 7.150,-
HMD 340/2500	3.400 mm	2.500 kg	2.500 mm	680 kg	€ 7.325,-
HMD 400/2500	4.000 mm	2.500 kg	2.800 mm	710 kg	€ 7.500,-

Options

- Lifting mast accessories

See page 55

ACCESSORIES FOR LIFTING MASTS

Tilting cylinder



Option	Description	Price
Tilting cylinder (HM)	Piston diameter 50 mm, stroke 200 mm, retracted length center to center 460 mm, with hoses, for lifting masts till 1600kg, including balancing valve. (Cat. 2 - Cat. 2)	€ 350,-
Tilting cylinder (HMD and HMZ)	Piston diameter 60 mm, stroke 250 mm, retracted length center to center 510 mm, with hoses, for lifting masts till 3000kg, including balancing valve. (Cat. 2 - Cat. 2)	€ 375,-
Sideshift (HM and HMD)	Piston diameter 60 mm, stroke 250 mm, retracted length center to center 510 mm, with hoses, for lifting masts till 3000kg, including balancing valve. (Cat. 2 - Cat. 3)	€ 375,-
Sideshift (HM/HMD)	FEM2 Sideshift on fork carriage, stroke 200 mm (fork carriage width 1000 mm (HM), 1200 mm (HMD)), including hydraulic connection on fork carriage	€ 1.150,-
Hydraulic connection	Double-action hydraulic connection on fork carriage	€ 325,-

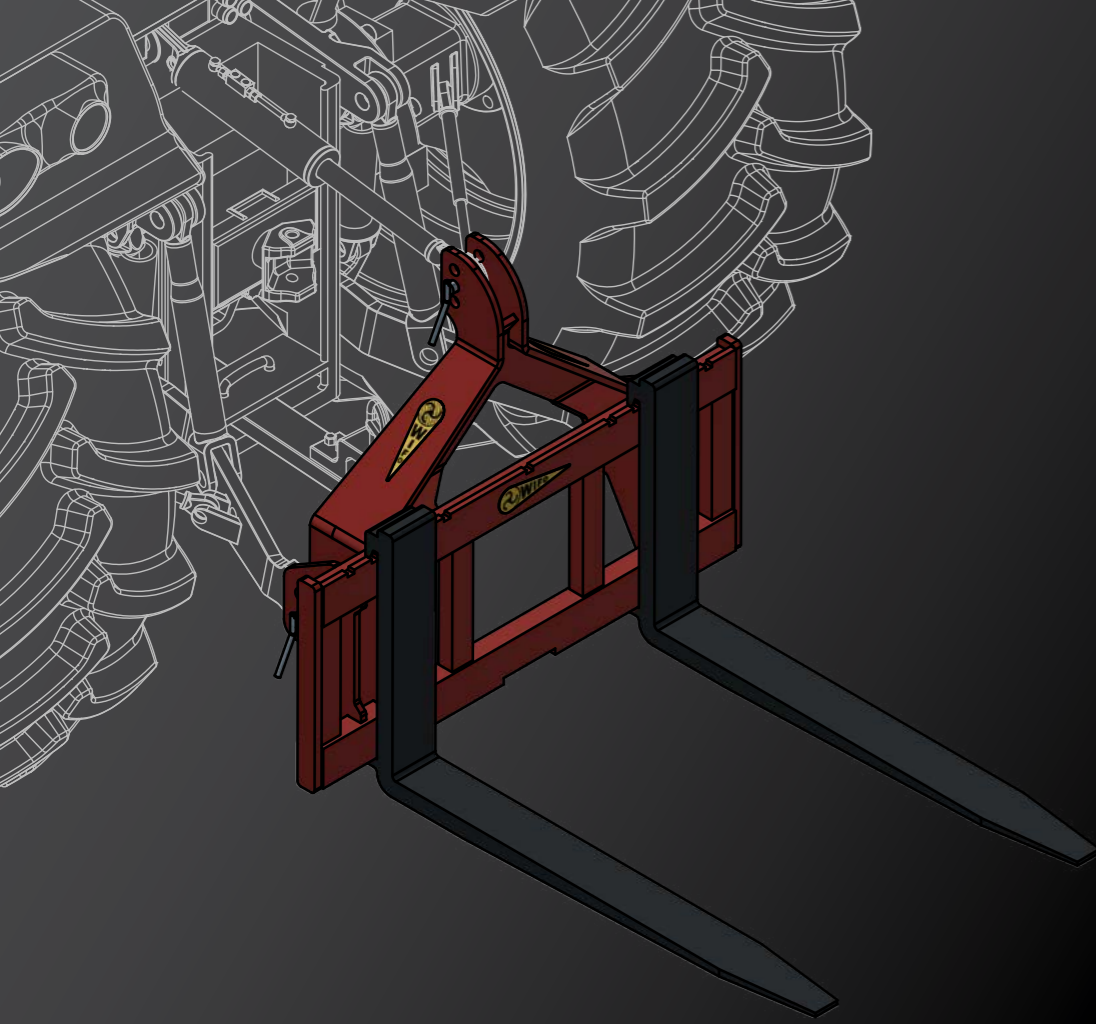

PALLET CARRIER WITH ADJUSTABLE FORKS



PP25 Three-point hitch



- Pallet carrier suitable for transport of pallets and boxes
- Strong, robust frame
- With FEM 2/3/4 fork carriage
- **Beware. Standard without attachment parts and forklift forks. See options.**

Type	Maximum load	Height of the fork carrier (FEM)	Fork carrier width	Weight	Price
PF25	2.500 kg	FEM2: 407 mm	1.200 mm	85 kg	€ 750,-
PF35	3.500 kg	FEM3: 508 mm	1.200 mm	115 kg	€ 900,-
PF45	5.000 kg	FEM4: 635 mm	1.200 mm	150 kg	€ 1.250,-

PP25 Three-point hitch



Attachment parts

- Front loader connection (Euro) € 225,-
- Three-point hitch (cat. 2) connection € 225,-
- Rapid coupling (FEM) € 400,-
- Attachment parts for frontloader/telehandler/shovel See page 67

PP25 Three-point hitch



Type forklift forks	Dimensions forks	Suitable for	Maximum load	Weight per set	Price
Fixed	FEM2A 100x40x1200 mm	PF25	2.500 kg	95 kg	€ 475,-
Fixed	FEM3A 125x45x1200 mm	PF35	3.500 kg	150 kg	€ 675,-
Fixed	FEM4A 150x60x1200 mm	PF45	5.000 kg	190 kg	€ 1.150,-
Folding	100x50x1200 mm	PF25	2.500 kg	140 kg	€ 1.050,-
Folding	100x50x1200 mm	PF35	3.500 kg	170 kg	€ 1.175,-

TOOL CARRIERS

Compact and organised equipment storage

For easy and fast movement of agricultural machinery in a workshop or shed, WIFO has developed its range of tool carriers. The compact tool carriers are easily picked up with the forklift forks and are ideal for moving machinery such as tillers, ploughs, cultivators and seeders. With the tool carriers, machinery are placed in the right place even more easily, resulting in compact and organised storage.



 **VIDEO**
Scan the QR-code

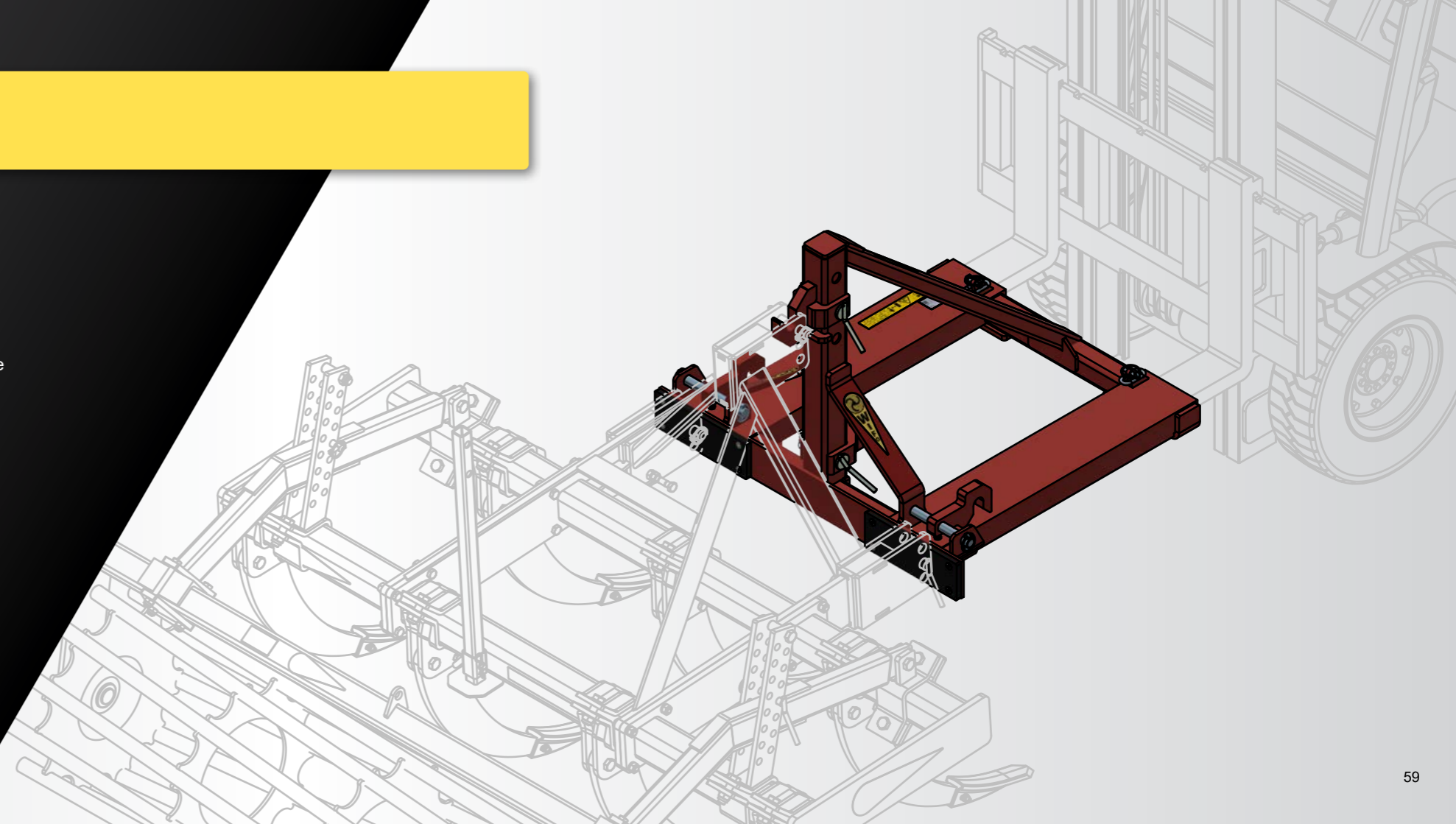

TOOL CARRIER FOR THREE-POINT HITCH EQUIPMENT



WDH-VZ

- Tool carrier for moving three-point hitch equipment (Cat. 2 and Cat. 3)
- Toplink pin in height adjustable in three positions
- Equipped with a tipper pin and catch hooks for semi-mounted machines
- Fork pockets: 150x66-L1000 mm, c.t.c. 730 mm



WDH-VZ + K50 tow ball coupler

Type	Max. capacity	Weight	Price
WDH-VZ	2.500 kg	150 kg	€ 1.375,-



WDH-VZ + K80 tow ball coupler

Options

- Tipper hitch pin Ø35 / tow ball coupler K50 combination (detachable)
- Tow ball coupler K80 (detachable)
- Attachment parts for frontloader/telehandler/shovel

€ 150,-

€ 400,-

On request

TOOL CARRIER FOR THREE-POINT HITCH EQUIPMENT (HEAVY DUTY)



WDH-VSZ

- Heavy-duty tool carrier for moving three-point equipment (Cat. 2 and Cat. 3)
- Toplink pin height adjustable in three positions
- Equipped with a tipper pin and catch hooks for semi-mounted machines
- Fork pockets: 215x75-L1200 mm, h.o.h. 900 mm



WDH-VSZ

Type	Max. capacity	Weight	Price
WDH-VSZ	5.000 kg	280 kg	€ 1975,-

Options

- Tow ball coupler K50 (detachable)
- Tow ball coupler K80 (detachable)
- Attachment parts for frontloader/telehandler/shovel



▶ Video

€ 225,-

€ 475,-

On request

WWW.WIFO.NL/EN

VISIT WIFO.NL
Scan the QR code



Our website offers a complete overview of our range of attachments and agricultural machinery, including spare parts books and manuals. The website also offers useful tools such as the residual capacity calculator, which allows you to quickly determine how much capacity is still available for a specific attachment.

CALCULATION OF THE RESIDUAL CAPACITY
Calculate the residual capacity of your attachments

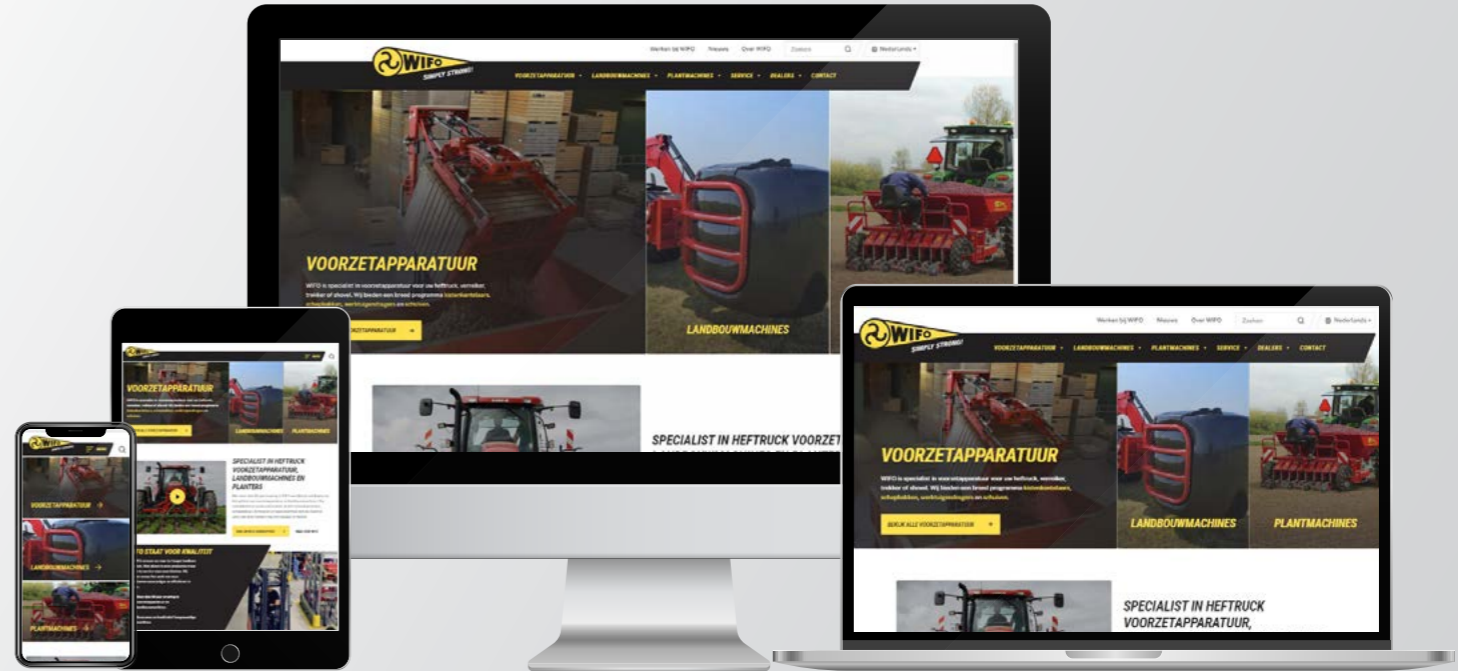

MEASUREMENT OVERVIEW OF ATTACHMENTS

Euro connection (for front loaders)

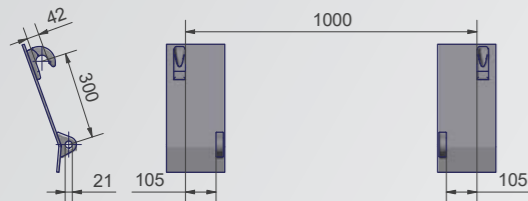

Three-point hitch connection

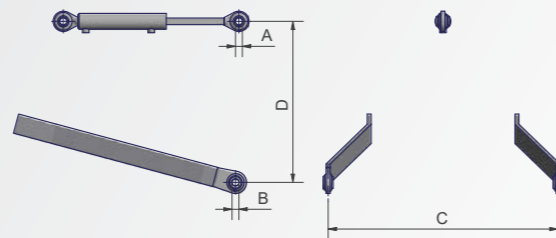

	A	B	C	D
Category 1	19 mm	22 mm	718 mm	460 mm
Category 2	26 mm	29 mm	870 mm	610 mm
Category 3	32 mm	37 mm	1010 mm	685 mm

Fork carrier dimensions

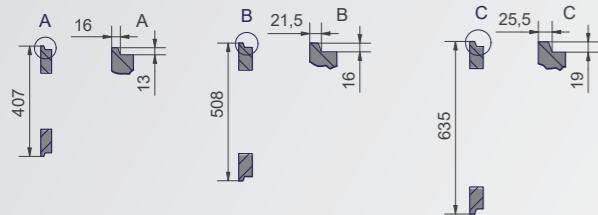

FEM2

FEM3

FEM4

SPARE PARTS

Are you looking for specific spare parts? We will be happy to help you!

+31 (0)518 745038

+31 (0)518 411318

spareparts@wifo.nl

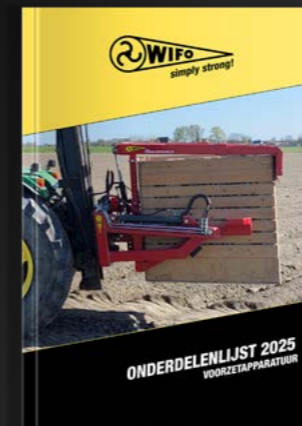

ATTACHMENT PARTS

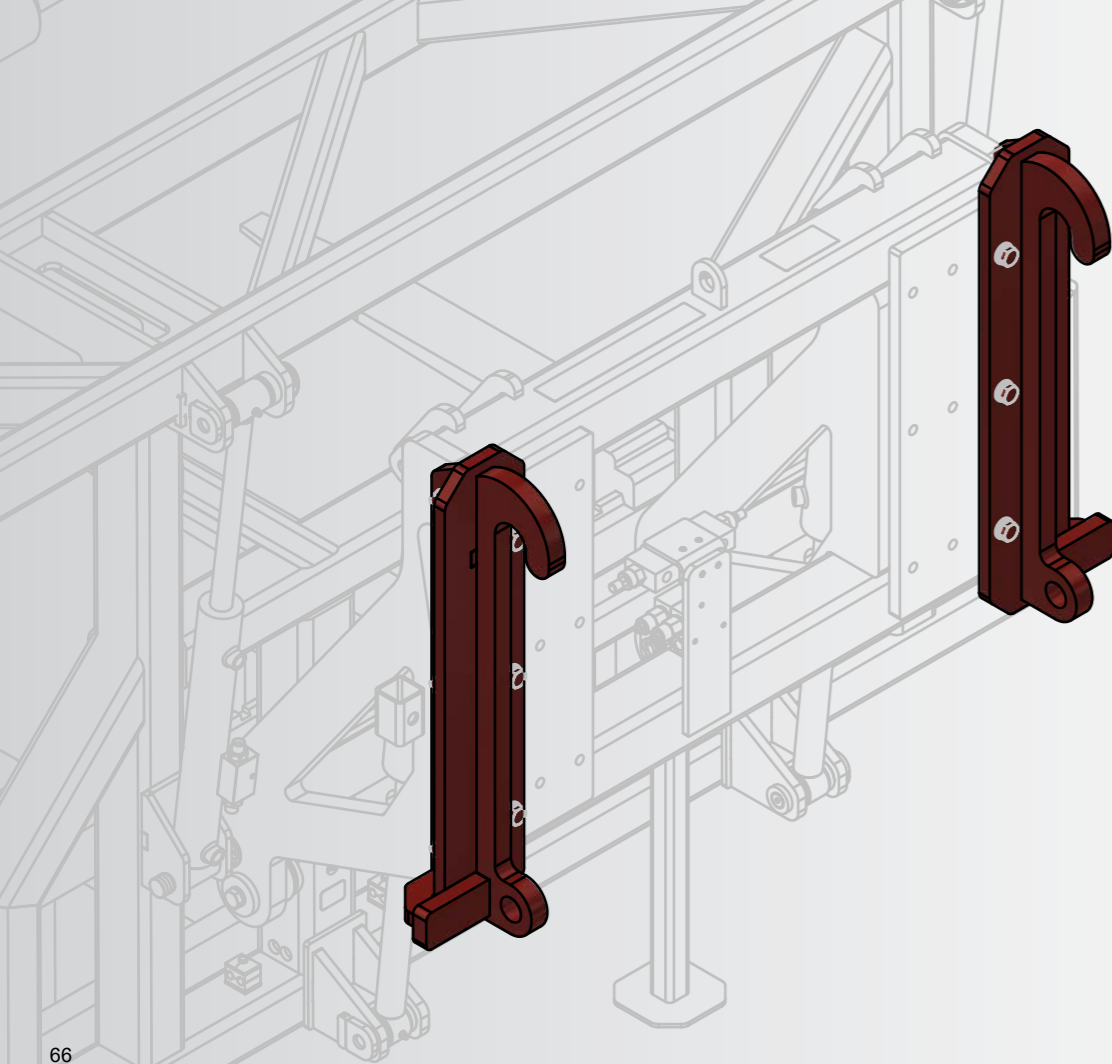

ACCORD	€ 225,-	JCB	€ 425,-
AHLMANN	€ 425,-	JCB Quick-Fit	€ 450,-
AVANT	€ 300,-	JOHN DEERE COMPACT (frontloader)	€ 300,-
BOBCAT (plate)	€ 400,-	JOHN DEERE (telehandler)	€ 450,-
BOBCAT (telehandler)	€ 500,-	KRAMER	€ 425,-
CATERPILLAR (plate)	€ 400,-	LIEBHERR	€ 425,-
CATERPILLAR (telehandler)	€ 450,-	MAILLEUX	€ 325,-
CLAAS Kramer/Scorpion	€ 450,-	MANITOU Maniscopic	€ 500,-
DIECI	€ 450,-	MATBRO	€ 450,-
Three point hitch cat. 2 (machine side)	€ 225,-	MERLO	€ 425,-
Three point hitch cat. 3 (machine side)	€ 275,-	NEW HOLLAND	€ 425,-
Three point hitch cat. 2 Walterscheid (equipment side)	€ 1.025,-	SCHÄEFF	€ 425,-
Three point hitch cat. 3 Walterscheid (equipment side)	€ 1.100,-	SCHÄFFER	€ 525,-
Euro (frontloader)	€ 225,-	TEREX	€ 425,-
Euro rapid coupling (frontloader, equipment side)	€ 350,-	VERACHTERT SW-2003	€ 1.000,-
FEM2 attachment	€ 225,-	VERACHTERT CW-10 (hamerstoel)	€ 275,-
FEM3 attachment	€ 250,-	VERACHTERT CW-30 (hamerstoel)	€ 500,-
FEM2 rapid coupling	€ 375,-	VOLVO L50-L120	€ 450,-
FEM3 rapid coupling	€ 425,-	VOLVO L150-L180	€ 750,-
GENIE/TEREX	€ 375,-	WEIDEMANN	€ 400,-
GIANT	€ 375,-	ZETTELMEYER	€ 450,-



TERMS & CONDITIONS

With the appearance of this price list all previous price lists of WIFO expire. All prices are in Euros and are not binding. Moreover, all prices exclude VAT. All prices and manuals of our products can be found on www.wifo.nl. Price and construction changes reserved. All sizes, weights, capacities, etc. quoted are approximate.

All our quotations, all orders placed with us and all contracts concluded with us, are subject to the METAALUNIE CONDITIONS. These conditions are filed with the register of the District Court of Rotterdam.

Upon delivery of a WIFO product to the end user, the seller ensures the machine is safe and delivered with the user manual and safety regulations included.

Complaints within 8 days.

Returns

Returns are only allowed after approval by WIFO-Anema Bv. Returns will not be credited when articles are used, assembled, painted or damaged and not saleable by WIFO. Returns should always be free of charge. An unaccepted return by WIFO will not release a customer from its commitments.

Finishing

WIFO products are supplied as standard in red top coat (RAL 3002). Anthracite (RAL 7021) is applied on request.

KvK: 01055959

BTW nr.: NL008716390B01

MORE THAN 60 YEARS OF EXPERIENCE

CURIOUS ABOUT 60 YEARS OF WIFO?
Check out the story behind our beautiful company here.



WE ARE WIFO!
To know more about WIFO, watch the video...



1961
Establishment of WIFO-Anema BV by Wijtse Anema and son Fokke Anema

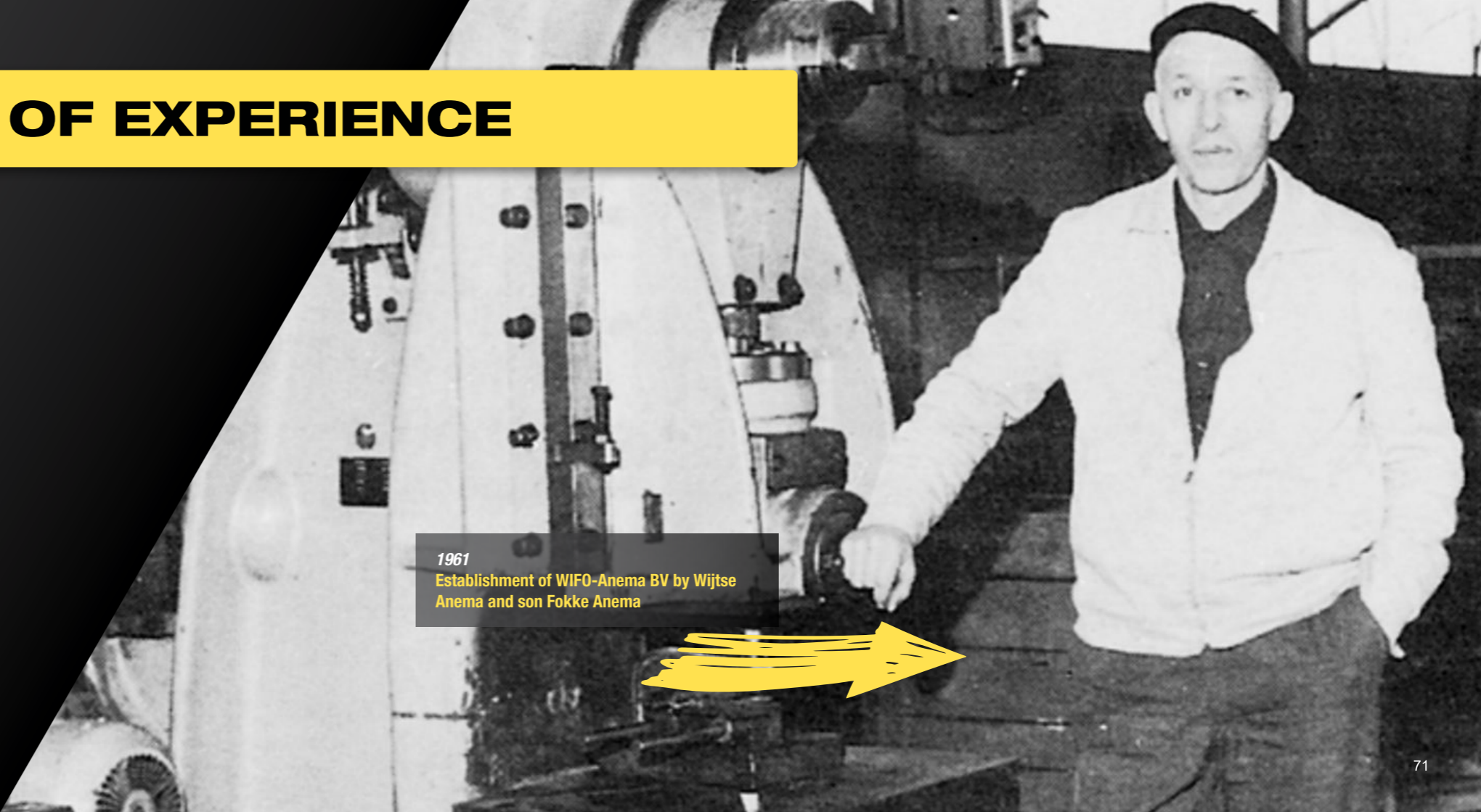

**SIMPLY!
STRONG.**

**SIMPLY!
STRONG!**



 Hegebeintumerdyk 37 | 9172 GP | Ferwert | The Netherlands

 +31 (0)518 411318

 info@wifo.nl

 [@wifoanema](https://www.facebook.com/wifoanema)

 [@wifoanemabv](https://www.instagram.com/wifoanemabv)